

# Scale and Proportion



# Scale





# The Hummingbirds

Robert Lostutter





Relief from great temple of Amun





# Hierarchical scale: relief from great temple of Amun

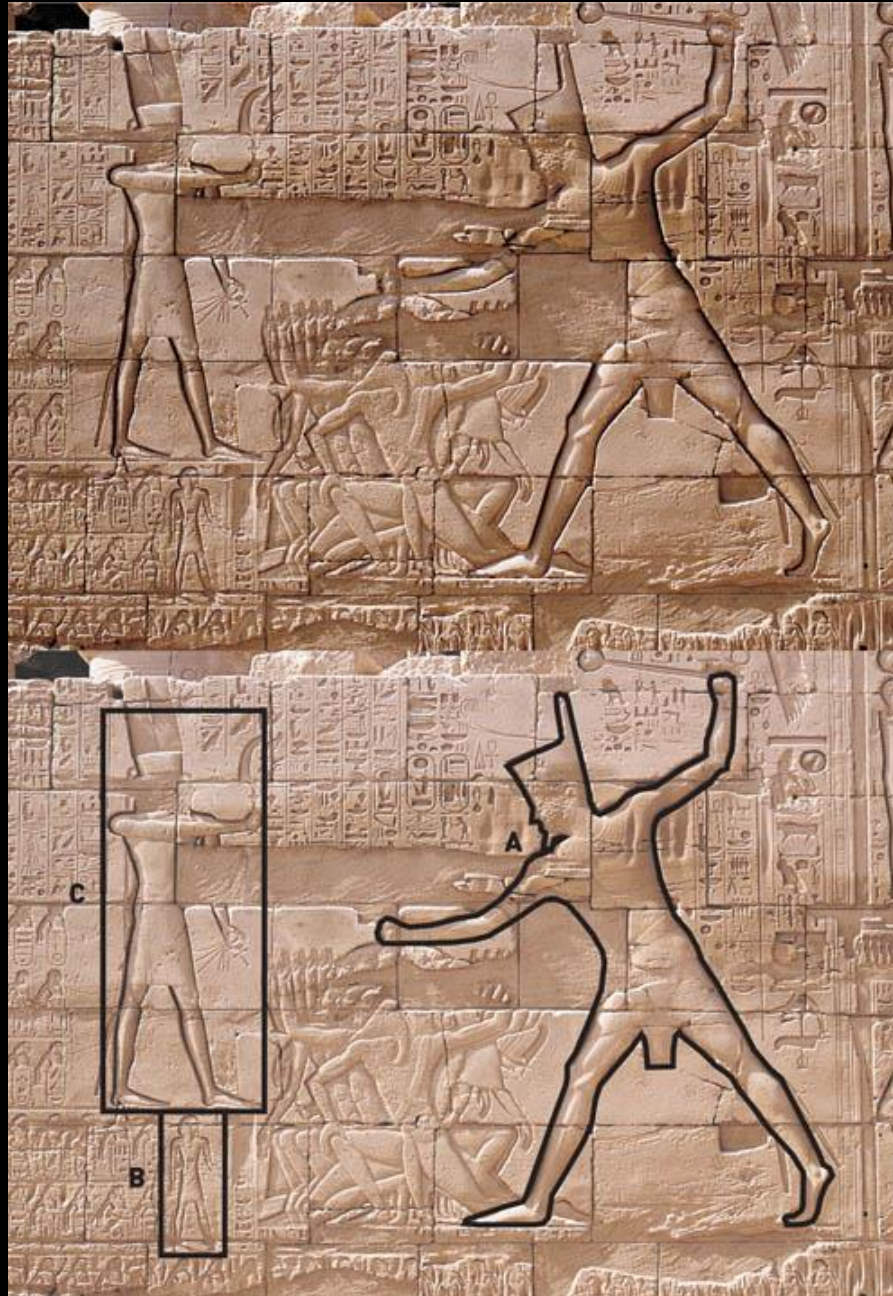

# Madonna in a Church

Jan van Eyck









# Proportion



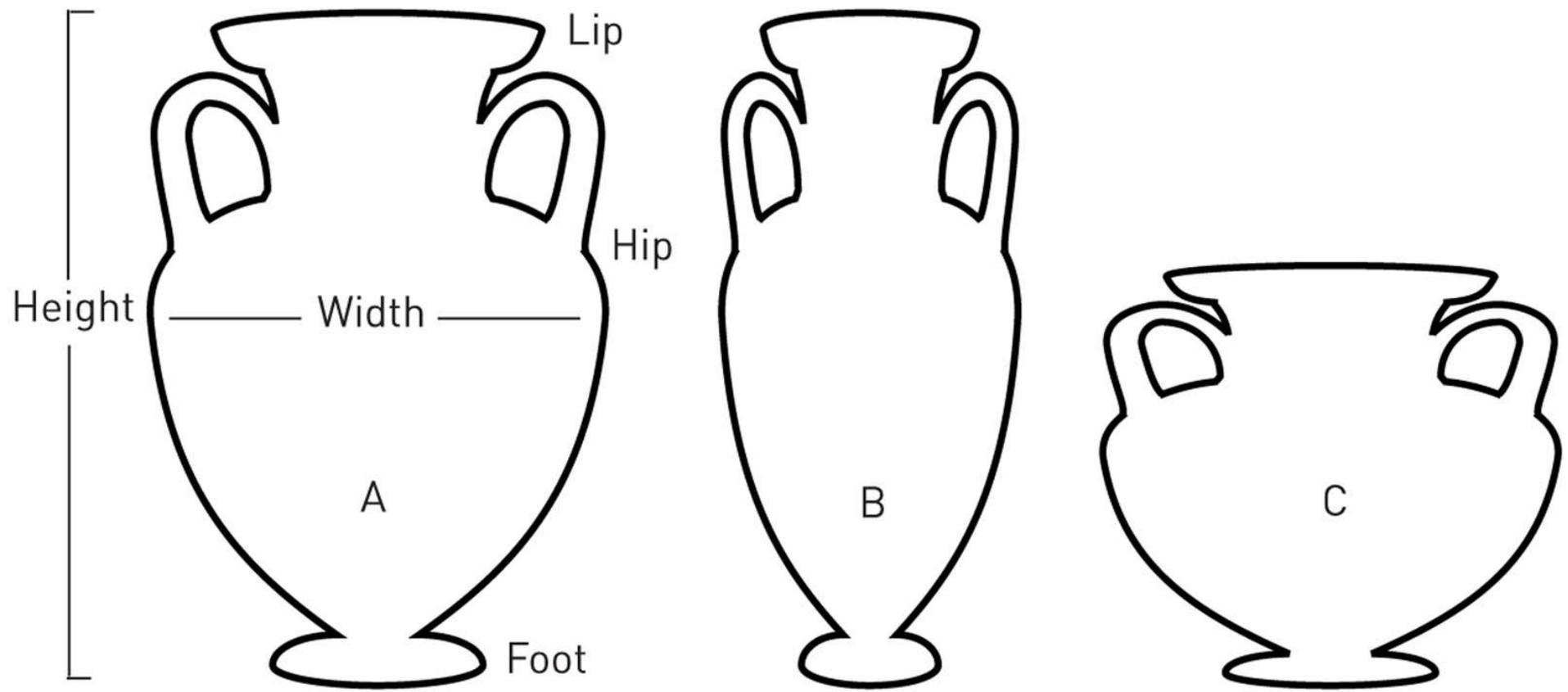



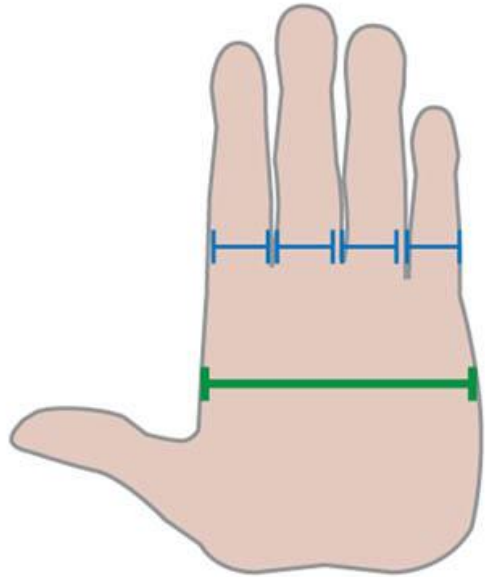

4 fingers = 1 palm

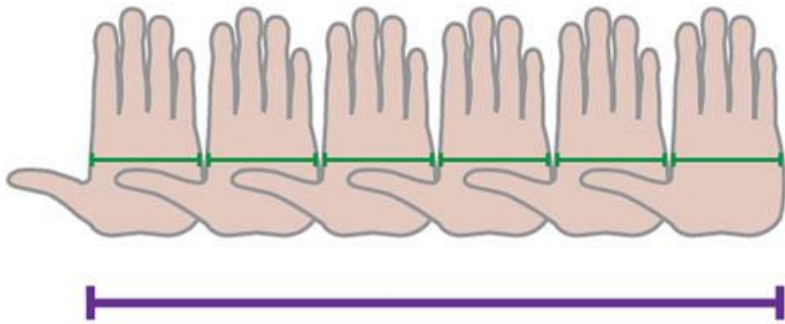

6 palms = 1 cubit

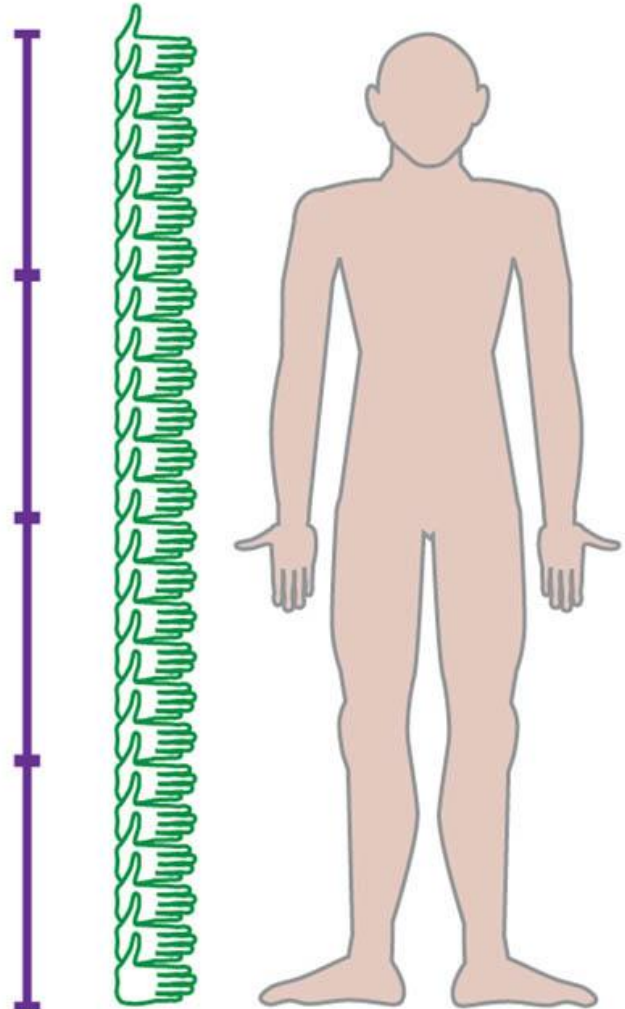

4 cubits = 1 man's height  
(24 palms)

Figure of Oni

Nigerian Ife artist







# The Golden Section

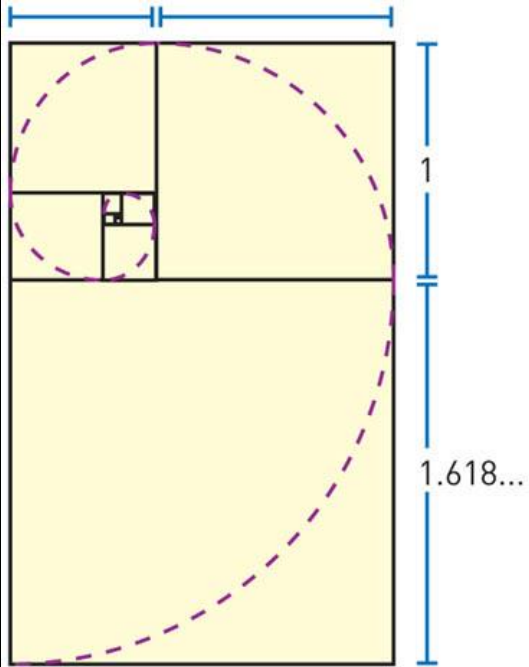

Golden Mean  
1:1.6180337...

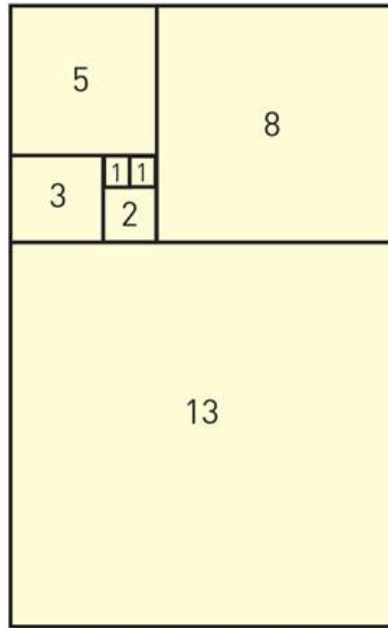

Fibonacci Sequence  
1, 1, 2, 3, 5, 8, 13,...

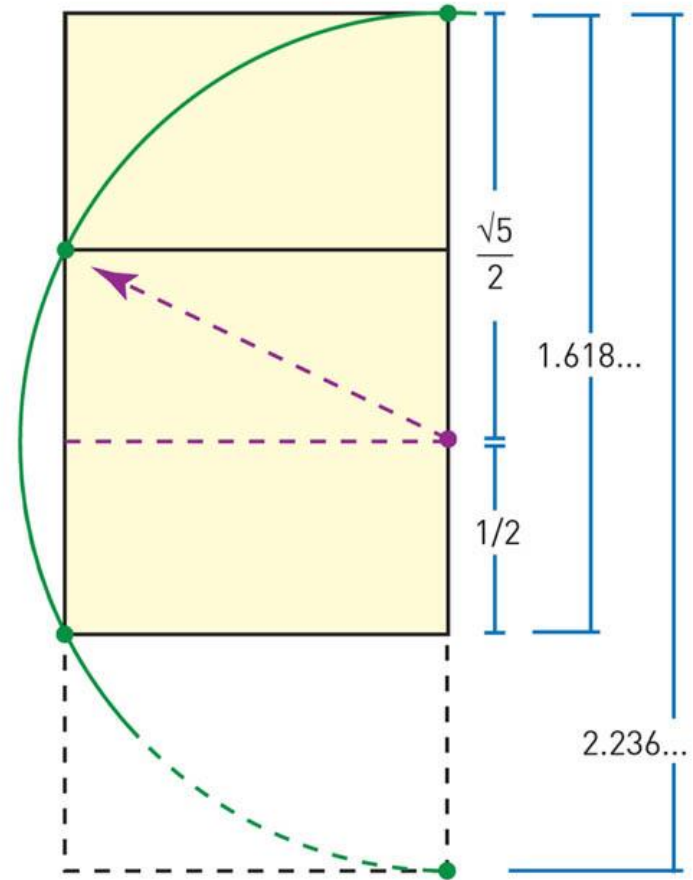

Root 5 Rectangle

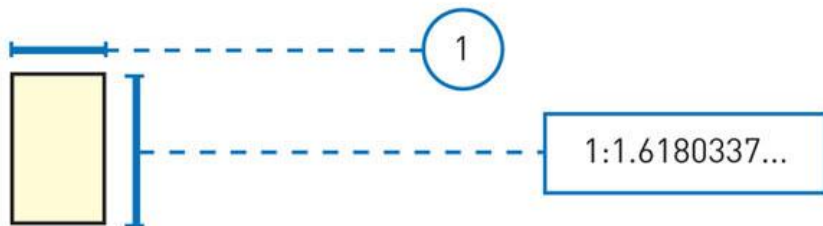



Poseidon (or Zeus)







# Fading Away

Henry Peach Robinson

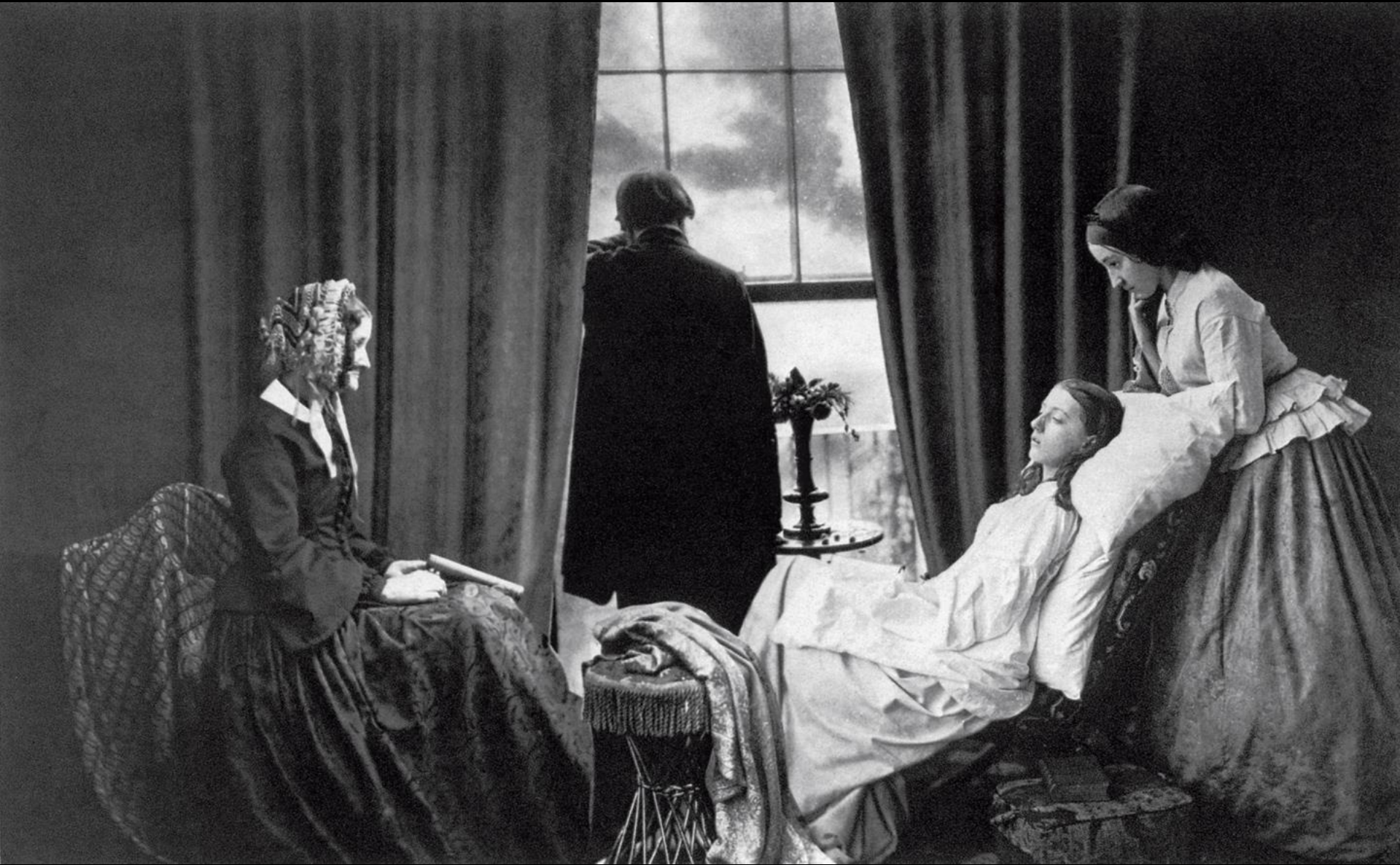

# Fading Away (Proportional Analysis)

Henry Peach Robinson

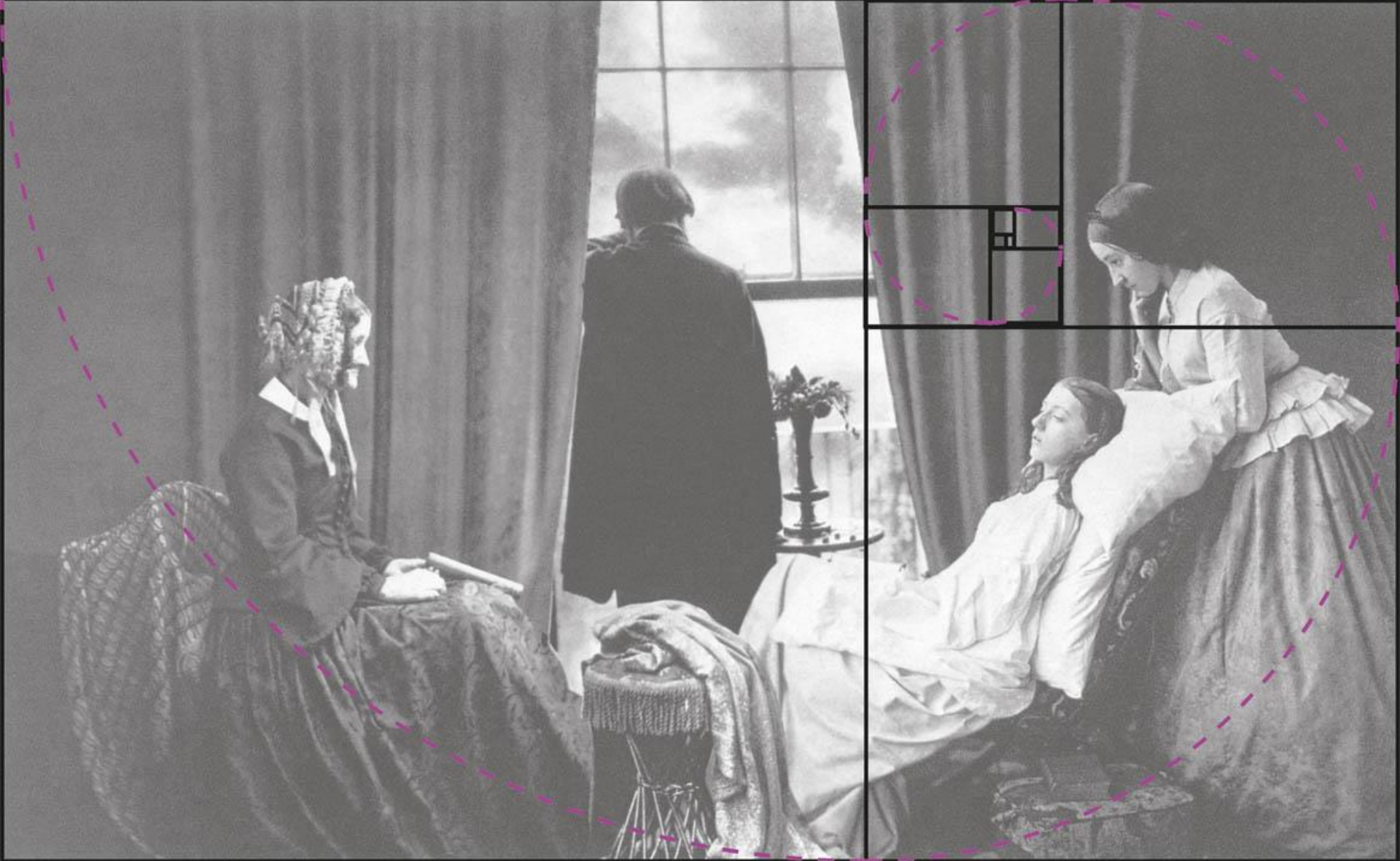



Parthenon

Iktinos and Kallikrates



# Use of Golden Section in design of the Parthenon

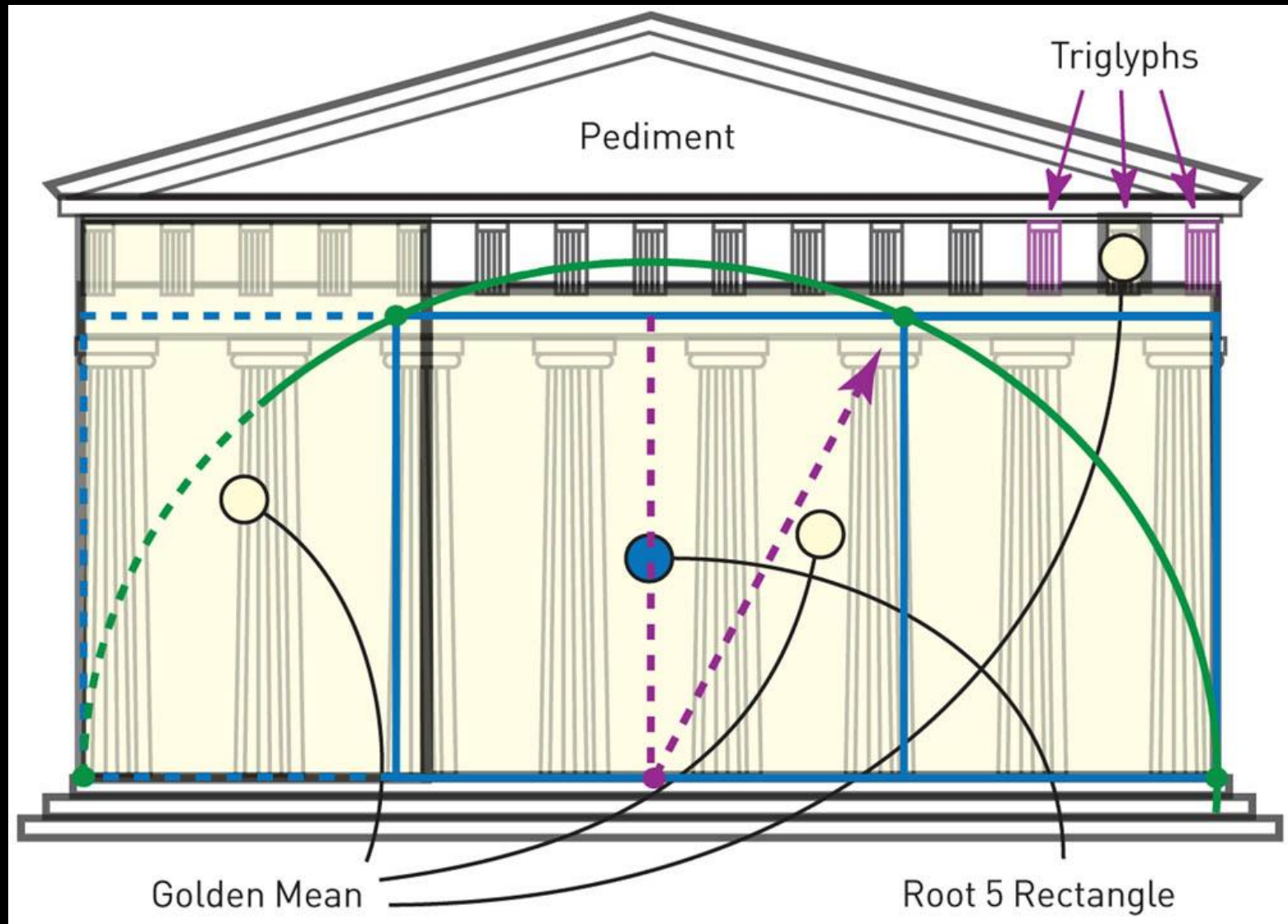



When a Yoruba sculptor created a human form, he or she made this body part disproportionately large:

- a. feet
- b. hands
- c. head
- d. torso
- e. none of these body parts

When a Yoruba sculptor created a human form, he or she made this body part disproportionately large:

- a. feet
- b. hands
- c. head
- d. torso
- e. none of these body parts



Something done on a monumental scale usually indicates \_\_\_\_\_ .

- a. epic virtues
- b. heroism
- c. bravery
- d. admiration
- e. all of these answers

Something done on a monumental scale usually indicates \_\_\_\_\_ .

- a. epic virtues
- b. heroism
- c. bravery
- d. admiration
- e. all of these answers



This Greek sculptor wrote a treatise on how to create a statue of a human being with perfect proportions.

- a. Plato
- b. Aristotle
- c. Phidias
- d. Michelangelo
- e. Polykleitos

This Greek sculptor wrote a treatise on how to create a statue of a human being with perfect proportions.

- a. Plato
- b. Aristotle
- c. Phidias
- d. Michelangelo
- e. Polykleitos



This use of scale can create an abnormal or supernatural effect, and was used by the Surrealists to do just that.

- a. proportion
- b. distorted scale
- c. monumental scale
- d. small scale
- e. balance

This use of scale can create an abnormal or supernatural effect, and was used by the Surrealists to do just that.

- a. proportion
- b. distorted scale
- c. monumental scale
- d. small scale
- e. balance

Raphael's School of Athens depicts this:

- a. a gathering of great scholars
- b. the building where philosophy was taught
- c. a Turkish bath
- d. a group of figures with large heads
- e. artists at work on Greek art



Raphael's School of Athens depicts this:

- a. a gathering of great scholars
- b. the building where philosophy was taught
- c. a Turkish bath
- d. a group of figures with large heads
- e. artists at work on Greek art

In Egyptian art the Pharaoh was almost always depicted this way.

- a. small in relation to other objects
- b. the same as other figures
- c. along the edge of the work
- d. as the largest of all figures
- e. lying down

In Egyptian art the Pharaoh was almost always depicted this way.

- a. small in relation to other objects
- b. the same as other figures
- c. along the edge of the work
- d. as the largest of all figures
- e. lying down



Robert Lostutter creates his work with a particular scale in mind. That scale relates to these animals:

- a. birds
- b. elephants
- c. whales
- d. insects
- e. microbes

Robert Lostutter creates his work with a particular scale in mind. That scale relates to these animals:

- a. birds
- b. elephants
- c. whales
- d. insects
- e. microbes

Scale can be used to indicate importance but not \_\_\_\_\_.

- a. size
- b. bigness
- c. significance
- d. smallness
- e. none of these answers



Scale can be used to indicate importance but not \_\_\_\_\_.

- a. size
- b. bigness
- c. significance
- d. smallness
- e. none of these answers

Henry Peach Robinson created his photographic work *Fading Away* by using a Golden \_\_\_\_\_ for the format dimensions.

- a. triangle
- b. spiral
- c. square
- d. section
- e. harp

Henry Peach Robinson created his photographic work *Fading Away* by using a Golden \_\_\_\_\_ for the format dimensions.

- a. triangle
- b. spiral
- c. square
- d. section
- e. harp



A work that is created in small scale can communicate \_\_\_\_\_

- a. intimacy
- b. monumentality
- c. big ideas
- d. epic stories
- e. all of these answers

A work that is created in small scale can communicate \_\_\_\_\_

- a. intimacy
- b. monumentality
- c. big ideas
- d. epic stories
- e. all of these answers